



StudTrainer.com
advanced virility enhancement system
VIP TECH, INC.



ALWAYS CONSULT YOUR PHYSICIAN BEFORE BEGINNING ANY EXERCISE PROGRAM

EXERCISE PROGRAM

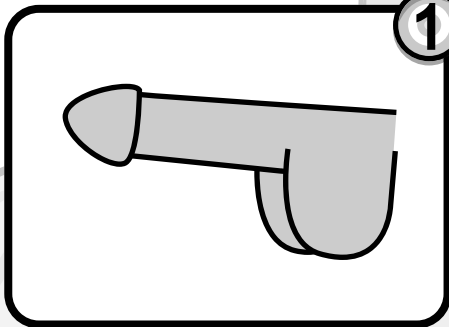

Begin session with a complete 100% erection. Strengthening of the penis occurs when the straps and weights are being held by an erection. Try to maintain an erection with the Official StudTrainer in place for as long as possible throughout the entire session. Even a small amount of weight will cause a marked effect. If the straps holding the weights should slip off, carefully put them back on after your erection has been renewed.

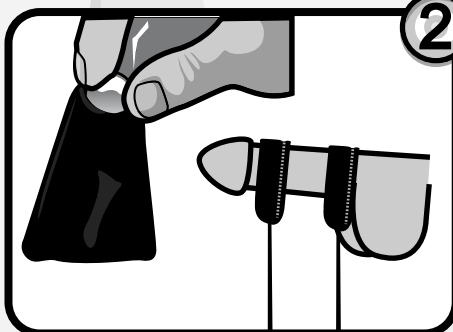

Start out light with 1 - 2 balls (2½ - 5oz) to warm up, then add weights as needed during your session. Carefully place straps on penis (place pads curved seam stitched edge inward towards pelvis making sure the cords of the straps are not twisted and swing freely), one strap at base of shaft and the other strap approximately ½ inch behind glans/head.

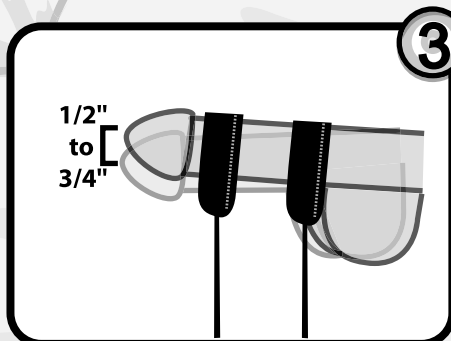

Begin penis pull-ups. Your penis will lift only about ½ - ¾ inch upward with each rep. Keep your penis as rigid as possible during each penis pull-up session of three (3) sets comprising of six (6) reps each. After each set of six (6) reps, finish last rep with a 15 - 30 second penis pull-up hold (use second-hand timer for each hold). Rest, then re-establish your erection and repeat the above (at least three (3) sets per session) until you are unable to keep your erection. For best results, perform one complete session of three (3) sets, three to four times a week with each session lasting at least 10 -15 minutes total.

EXERCISE PROGRAM

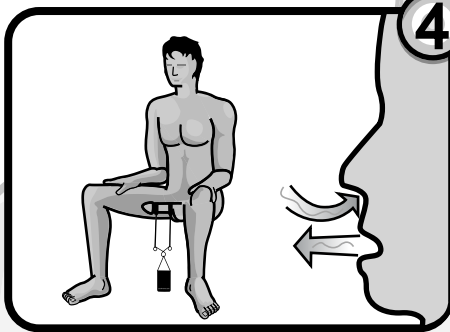

4

Sitting Position: Sit on edge of a seat, legs spread 2 - 2½ feet apart, hands on thighs, pelvis and penis area outward/forward. Breathe deeply and slowly through your nose, exhaling through your mouth during the entire penis pull-up session.

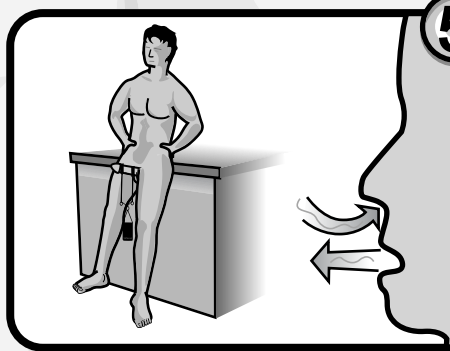

5

Standing, Lean-Back Position: Lean back and brace yourself against something. Position feet 2 - 2½ feet apart, hands on hips, tighten abdominal muscles, slightly bend knees, arch shoulders back, thrust pelvis and penis area outward/forward. Breathe deeply and slowly through your nose, exhaling through your mouth during the entire penis pull-up session.

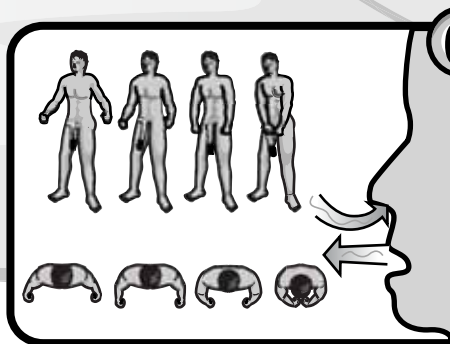

6

Standing Position: Feet 2 - 3 feet apart, tighten abdominal muscles, knees slightly bent, shoulders back, thrust pelvis and penis area outward/forward. Breathe deeply and slowly through your nose, exhaling through your mouth during the entire penis pull-ups session and optional arm action.

EXERCISE PROGRAM

7 **Optional Standing Position:**
Feet 2 - 3 feet apart, tighten abdominal muscles, knees slightly bent, shoulders back, thrust pelvis and penis area outward/forward. Breathe deeply and slowly through your nose, exhaling through your mouth during the entire penis pull-ups session and optional arm action.

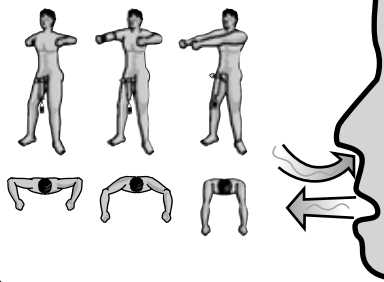
The illustration shows six figures demonstrating different body positions. The top row shows three standing figures: the first is upright, the second has arms extended forward, and the third has arms extended forward with a slight lean. The bottom row shows three kneeling figures: the first is on a flat surface, the second is on a raised surface with knees bent, and the third is on a raised surface with feet flat on the ground. To the right of these figures is a profile of a head with two curved arrows pointing towards the mouth, indicating breathing instructions.

8 Continue stimulation to glans/head for a continued erection during penis pull-up reps and hold back your ejaculation throughout the session.

The illustration shows a hand with the index finger pointing up. The hand is superimposed on a hexagonal background that contains the letters 'S' and 'P'.

9 **Optional: For the Advanced Trainer:**
Throughout the entire penis pull-ups session, imagine your penis growing then lift your testicles up, thrusting both testicles forward simultaneously while doing each rep.

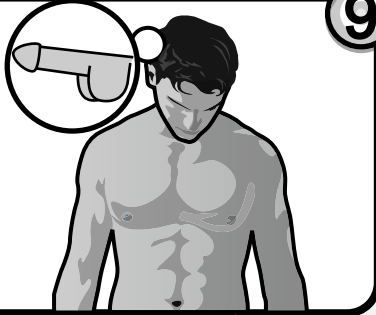
The illustration shows a man from the waist up, looking down at his groin. A magnifying glass is positioned over his groin area, with a circular inset showing a close-up of the penis.

How to get the Best Results...



Use warm baby oil.



Clear your thoughts; be serious and take your time during each session. Try to set aside a specific time for your session to achieve maximum results.

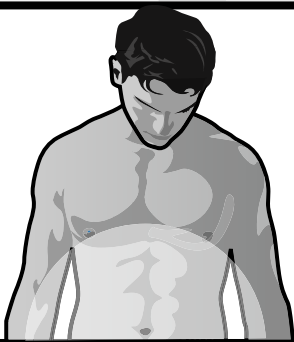

Concentrate during each session; with each rep, imagine a ball of white hot energy growing and building in your pelvic area to your glans/head. Although you may, at first, become so stimulated that you ejaculate during your session, this will not adversely affect your exercise regimen.

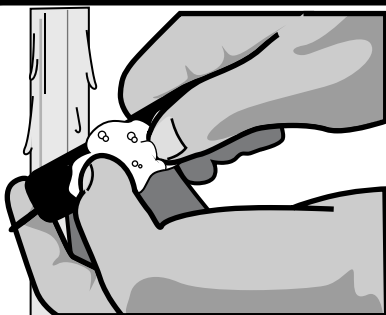

If needed, you can gently wash your cushion pads/straps with mild soap and rinse thoroughly with water then towel dry and/or let air dry.

Legal Agreement

Terms and Conditions of Purchase

Always consult your physician before beginning any exercise program

StudTrainer.com shall mean and include its predecessor entities, officers, agents, their predecessors, related companies or entities, successors in interest, officers, directors, employees, agents, sub-contractors and representatives.

LIMITED WARRANTY

StudTrainer.com warrants to Purchaser for a period of thirty (30) days from the date of delivery, that the Products, when shipped to Purchaser by StudTrainer.com shall conform in all material respects to the specifications of StudTrainer.com, as provided on the StudTrainer website or in other literature provided to Purchaser by StudTrainer.com; provided, however, that (a) the Products must be used under the prescribed conditions during such warranty period and (b) Products are also subject to the appropriate limitations or restrictions provided as peptide clauses found in the specifications. EXCEPT FOR THE FOREGOING WARRANTY, STUDTRAINER.COM DOES NOT WARRANT THE MERCHANTABILITY OR FITNESS FOR A PARTICULAR PURPOSE OF THE PRODUCTS OR THE PERFORMANCE OR NON-INFRINGEMENT THEREOF, DOES NOT MAKE AND HEREBY EXPRESSLY DISCLAIMS ANY WARRANTY, EXPRESS OR IMPLIED, WITH RESPECT TO THE PRODUCTS, SPECIFICATIONS, SUPPORT, SERVICE OR ANYTHING ELSE RELATING TO THE PRODUCTS AND DOES NOT MAKE ANY WARRANTY TO PURCHASER, PURCHASER'S CUSTOMERS OR THEIR AGENTS CONCERNING THE PRODUCTS. In addition, StudTrainer.com does not warrant that the use or sale of the products delivered hereunder will not infringe intellectual property rights covering the product itself or the use thereof in combination with other products or in the operation of any process.

LIMITED LIABILITY

PURCHASER ACKNOWLEDGES AND AGREES THAT STUDTRAINER.COM'S SOLE LIABILITY AND PURCHASER'S SOLE AND EXCLUSIVE REMEDY HEREUNDER SHALL NOT EXCEED THE AMOUNT PAID BY PURCHASER FOR SUCH PRODUCTS UNDER THE ORDER. SUCH LIMITATIONS ON STUDTRAINER.COM'S LIABILITY HEREUNDER SHALL APPLY EVEN IF STUDTRAINER.COM'S LIABILITY IS DUE IN WHOLE OR IN PART TO ITS OWN NEGLIGENCE. IN ORDER TO OBTAIN SUCH REMEDIES, PURCHASER SHALL AFFORD STUDTRAINER.COM PROMPT AND REASONABLE OPPORTUNITY TO INSPECT ALL PRODUCTS AS TO WHICH ANY CLAIM IS MADE THAT SUCH PRODUCTS DO NOT CONFORM TO THE WARRANTIES PROVIDED HEREIN. AT STUDTRAINER.COM'S OPTION, AND A CONDITION TO ANY WARRANTY CLAIMS HEREUNDER, PURCHASER SHALL ALLOW STUDTRAINER.COM TO TAKE CONTROL OF SUCH PRODUCTS AND DIRECT THEIR DISPOSAL. UPON RECEIPT OF SHIPPING INSTRUCTIONS FROM STUDTRAINER.COM, PURCHASER SHALL RETURN TO STUDTRAINER.COM ALL PRODUCTS ALLEGEDLY NOT CONFORMING TO THE SPECIFICATIONS.

WAIVER OF LIABILITY

Purchaser is fully aware of the risks and hazards connected with the use of the StudTrainer, including the risk of physical injury or disability as the result of such injury, and hereby assumes all RISKS OF LOSS, PROPERTY DAMAGE OR PERSONAL INJURY that may be sustained, or any loss or damage to property as a result of using the StudTrainer, Purchaser hereby AGREES TO INDEMNIFY AND HOLD HARMLESS StudTrainer.com from any loss, liability, damage or costs that may incur due to the use of the StudTrainer.

Legal Agreement Cont.

WAIVER OF CONSEQUENTIAL DAMAGES

IN NO EVENT SHALL STUDTRAINER.COM OR ITS AFFILIATES OR THEIR RESPECTIVE OFFICERS, DIRECTORS, REPRESENTATIVES AND EMPLOYEES BE LIABLE TO PURCHASER OR ITS AFFILIATES OR THEIR RESPECTIVE OFFICERS, DIRECTORS, REPRESENTATIVES AND EMPLOYEES, WHETHER BASED IN CONTRACT, TORT, WARRANTY OR ANY OTHER LEGAL OR EQUITABLE GROUNDS, FOR ANY LOSS OF THE INCOME, PROFIT OR SAVINGS OR COST OF CAPITAL OF PURCHASER OR ITS AFFILIATES, FOR ANY INDIRECT, INCIDENTAL OR CONSEQUENTIAL DAMAGES OR FOR ANY EXEMPLARY, SPECIAL OR PUNITIVE DAMAGES OF ANY KIND, RESULTING FROM OR RELATING TO THE ORDER OR THE PRODUCTS DELIVERED HEREUNDER.

PURCHASER'S USE OF PRODUCTS

StudTrainer.com's products are intended primarily for entertainment and research purposes and, unless otherwise stated on product labels, on StudTrainer.com's website or in other literature furnished to Purchaser by StudTrainer.com, are not to be used for any other purposes, including but not limited to, medical or physical therapy for humans or animals. Purchaser acknowledges that the products have not been tested by StudTrainer.com for safety and efficacy in food, drug, medical device, cosmetic, commercial or any other use, unless otherwise stated in StudTrainer.com's literature furnished to Purchaser. Purchaser agrees to comply with instructions, if any, furnished by StudTrainer.com relating to the use of the products and not misuse the products in any manner. No products purchased from StudTrainer.com shall, unless otherwise stated, be considered to be foods, drugs, medical devices or cosmetics. StudTrainer.com is not a medical device and has not been approved by the United States Food and Drug Administration (FDA) nor has it received any medical device clearances.

PURCHASER'S REPRESENTATIONS AND INDEMNITY

Purchaser represents and warrants that it shall use all products ordered in lawful manner. Purchaser shall defend StudTrainer.com, its employees, agents, affiliates and contractors (the "StudTrainer.com Indemnitees"), and shall hold the StudTrainer.com Indemnitees harmless from and against all suits, actions, or proceedings, at law or in equity, and from all claims, costs, damages, losses and expenses (including, without limitation, attorney's fees, consultants' fees, experts' fees) of third parties that are related to or in connections with (1) the product sequences, if applicable, being wrongfully disclosed by Purchaser hereunder, (2) infringement, misappropriation, and/or conversion which are the direct result of StudTrainer.com's possession and/or use of such sequences disclosed by Purchase, if applicable, or (3) the death or bodily injury of any third party or the damage, loss or destruction of any tangible personal or real property arising from or related to Purchaser's use of the Products, or its manufacture of sale of any products or utilizing the products.

RELATIONSHIPS OF THE PARTIES

No formal business organization or relationship of any kind is established by this Agreement. The parties expressly agree that the relationship created by and arising out of this Agreement is that of independent contractors entering into arms-length transaction. Nothing contained in this Agreement is intended nor is to be construed so as to constitute Purchaser and StudTrainer.com as partners, agents or joint ventures with respect to this Agreement. Neither party hereto shall have any express or implied right or authority to assume or create any obligations on behalf of or in the name of the other party or to bind the other party to any Agreement or undertaking with any third party.

GOVERNING LAW; VENUE

This Agreement shall be subject to and construed in accordance with the laws of the State of Florida without regard to conflicts to law principles, as may be applicable to Agreements made and performed entirely in Florida. The exclusive venue for proceedings arising under this Agreement shall be a court of competent jurisdiction in Broward County, Florida.